

30 Series Resilient Surface Mounted Light Duty Flexible Expansion Joint Cover

LATHAM AUSTRALIA PTY LTD
 14 TENNYSON ROAD GLADESVILLE 2111 AUSTRALIA
 Phone: 61 2 9879 7888 Fax: 61 2 9879 7666
 Web: www.latham-australia.com



Scale: Approx. 50% Full Size
 All dimensions are to be verified before construction

Verified By..... Date.....

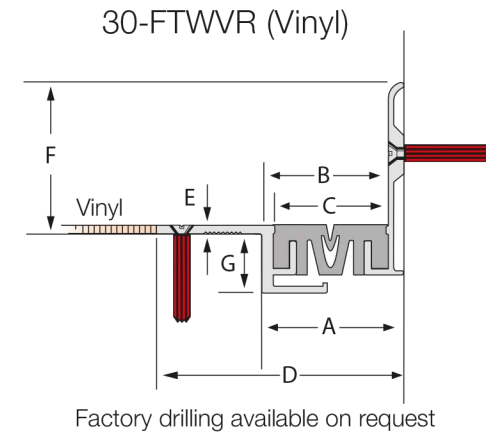
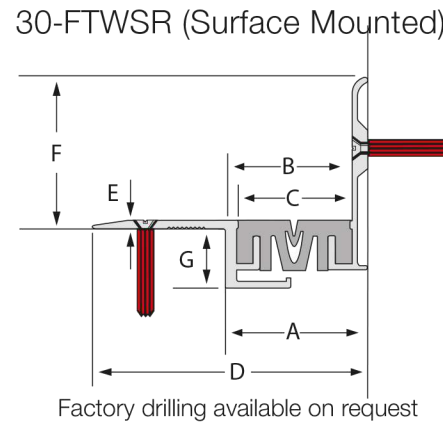
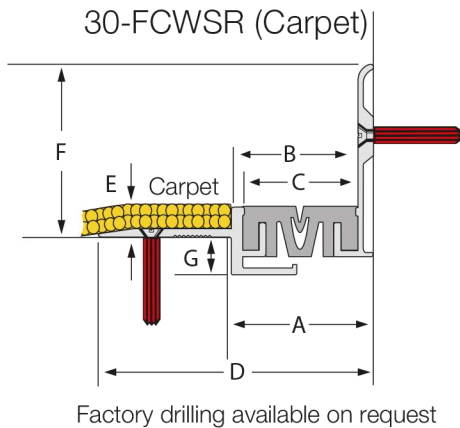
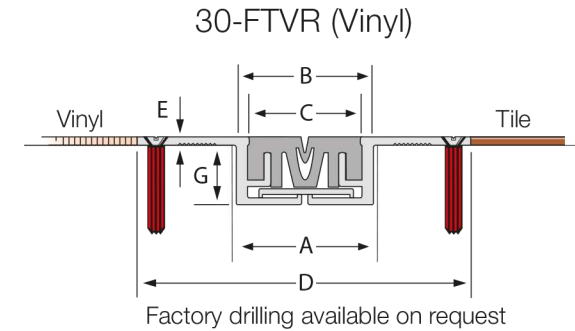
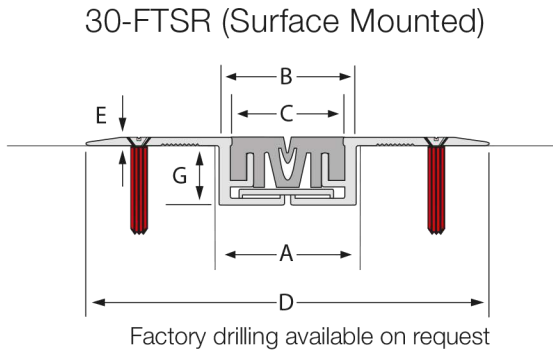
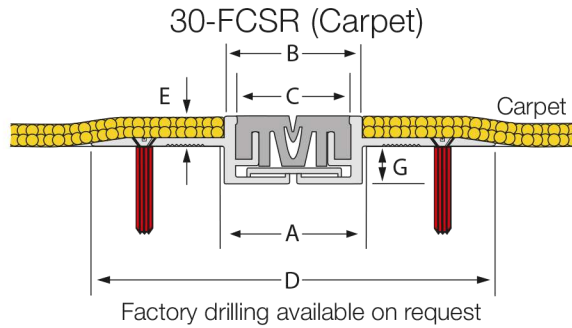

Aluminium Code	A	B	C	D	E	F	G	Movement	Total Available Movement	Overall Depth
30-FCSR	38	36	30	115	8		10	+/-3mm	6mm	18mm
30-FCWSR	38	33	30	85	8	38	10	+/-3mm	6mm	48mm
30-FTSR	38	36	30	115	3		20	+/-3mm	6mm	23mm
30-FTWSR	38	33	30	85	3	38	20	+/-3mm	6mm	58mm
30-FTVR	38	36	30	115	3		20	+/-3mm	6mm	23mm
30-FTWVR	38	33	30	85	3	38	20	+/-3mm	6mm	58mm

All dimensions are in millimetres.

Interior applications only.
 All mechanical expansion joint fixings by others.
 Design subject to change without notice

COPYRIGHT © 2019