

SCAL Carpet-Line Series - Carpet View

Flexible Expansion Joint Cover

LATHAM AUSTRALIA PTY LTD
 14 TENNYSON ROAD GLADESVILLE 2111 AUSTRALIA
 Phone: 61 2 9879 7888 Fax: 61 2 9879 7666
 Web: www.latham-australia.com



Illustrated: SCAL-25 Scale: Approx. Full Size
 All dimensions are to be verified before construction
 Verified By..... Date.....

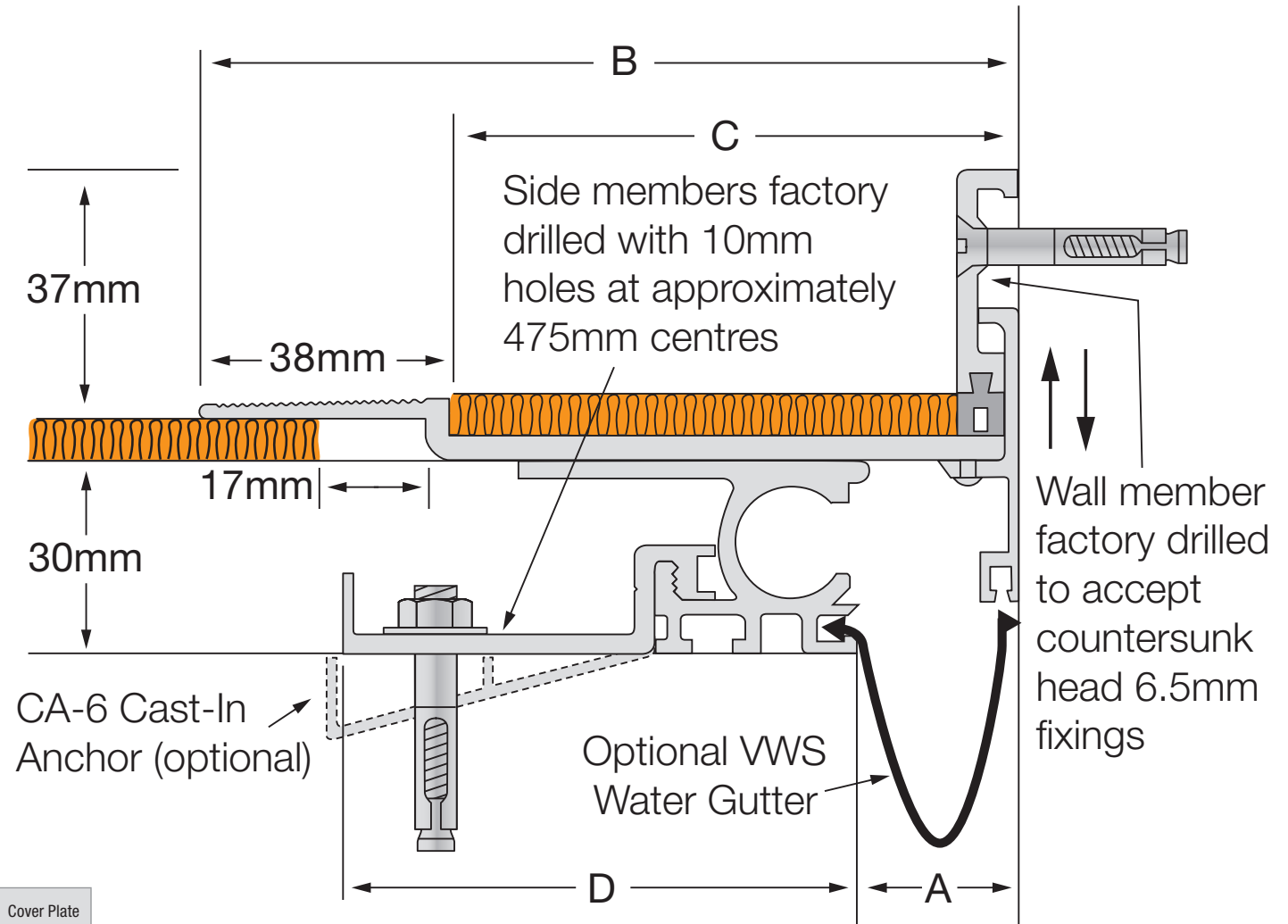

| Aluminium Code ribbed deck | A | B | C | D | Movement | Total Available Movement | Overall Depth | Cover Plate Thickness |
|-------------------------------|-----|-----|----|----|----------|--------------------------|---------------|-----------------------|
| SCAL-25 | 25 | 127 | 88 | 82 | +/-17mm | 34mm | 30mm | 9mm |
| SCAL-50 | 50 | 127 | 88 | 82 | +/-17mm | 34mm | 30mm | 9mm |
| SCAL-75 | 75 | 127 | 88 | 82 | +/-17mm | 34mm | 30mm | 9mm |
| SCAL-100 | 150 | 127 | 88 | 82 | +/-17mm | 34mm | 30mm | 9mm |

All dimensions are in millimetres.

Interior applications only.
 All mechanical expansion joint fixings by others.
 Design subject to change without notice