

SC + SCL Wall-Line Series - Surface Mounted

Flexible Expansion Joint Cover

LATHAM AUSTRALIA PTY LTD
 14 TENNYSON ROAD GLADESVILLE 2111 AUSTRALIA
 Phone: 61 2 9879 7888 Fax: 61 2 9879 7666
 Web: www.latham-australia.com



Illustrated: 25SC + 25SCL Scale: Approx. Full Size
 All dimensions are to be verified before construction

Verified By..... Date.....

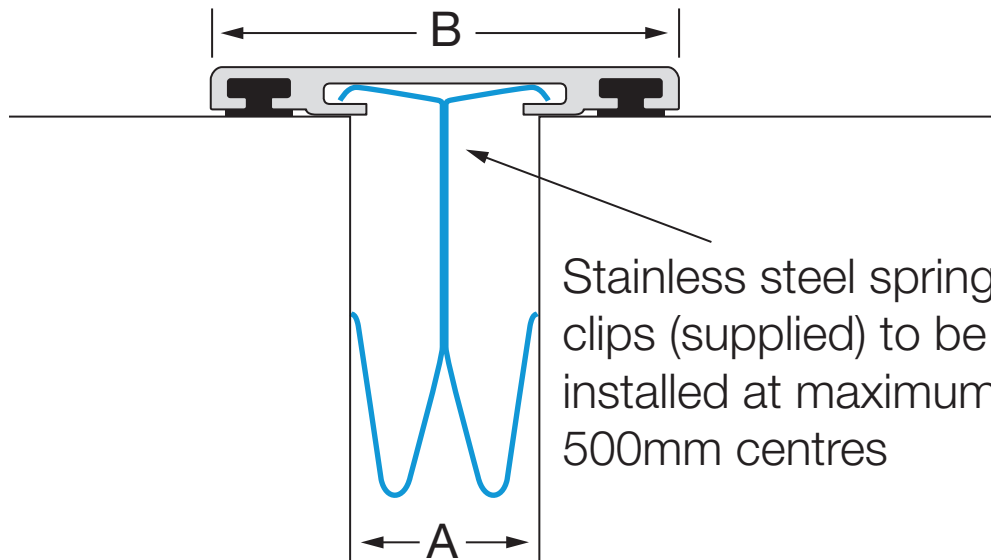

| Aluminium Code | A | B | Movement | Total Available Movement | Coverplate Depth |
|----------------|----|-----|----------|--------------------------|------------------|
| Type 25SC | 25 | 66 | +/-25mm | 50mm | 6mm |
| Type 50SC | 50 | 106 | +/-30mm | 60mm | 6mm |

All dimensions are in millimetres.

20 micron clear anodised aluminium finish (standard)
 or brass colour anodised aluminium finish (specify brass colour finish).

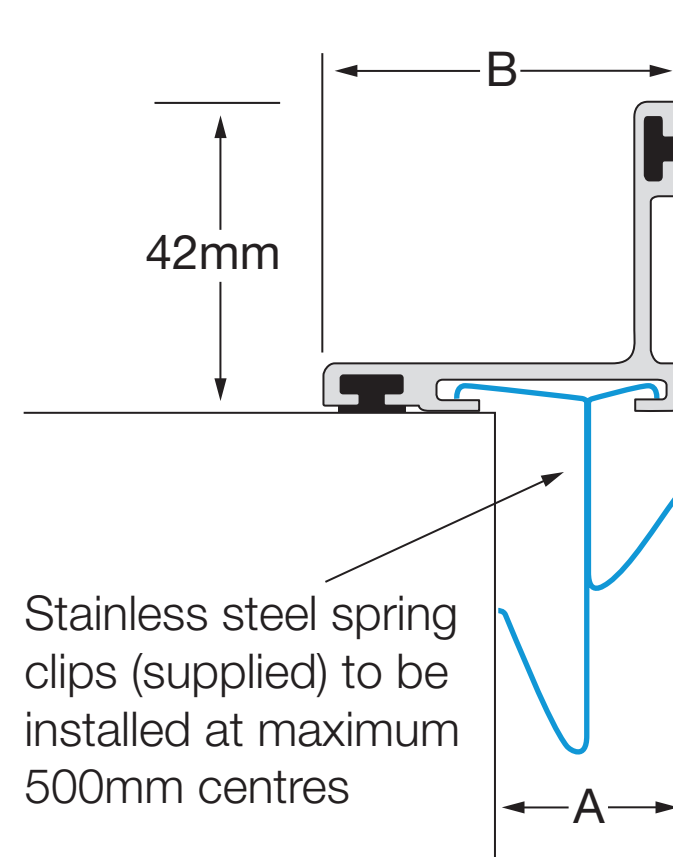

| Aluminium Code | A | B | Movement | Total Available Movement | Coverplate Depth |
|----------------|----|----|----------|--------------------------|------------------|
| Type 25SCL | 25 | 53 | +/-12mm | 25mm | 6mm |
| Type 50SCL | 50 | 90 | +/-15mm | 30mm | 6mm |

All dimensions are in millimetres.

Interior use only.
 All mechanical expansion joint fixings by others.
 Design subject to change without notice

COPYRIGHT © 2009

LATH3513