

# SAC + SACL Wall-Line Series -Acoustic Ceiling

Flexible Expansion Joint Cover

**LATHAM AUSTRALIA PTY LTD**  
 14 TENNYSON ROAD GLADESVILLE 2111 AUSTRALIA  
 Phone: 61 2 9879 7888 Fax: 61 2 9879 7666  
 Web: www.latham-australia.com



Illustrated: 25SAC + 25SACL Scale: Approx. Full Size  
 All dimensions are to be verified before construction

Verified By..... Date.....

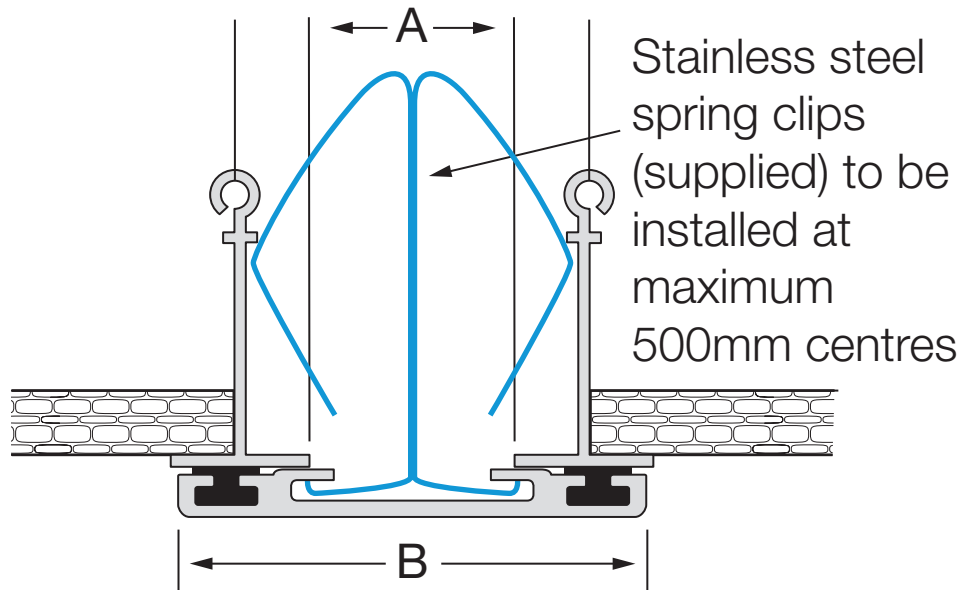

| Aluminium Code | A  | B   | Movement | Total Available Movement | Coverplate Depth |
|----------------|----|-----|----------|--------------------------|------------------|
| Type 25SAC     | 25 | 66  | +/-25mm  | 50mm                     | 6mm              |
| Type 50SAC     | 50 | 116 | +/-30mm  | 60mm                     | 6mm              |

All dimensions are in millimetres.

20 micron clear anodised aluminium finish (standard)  
 or brass colour anodised aluminium finish (specify brass colour finish).

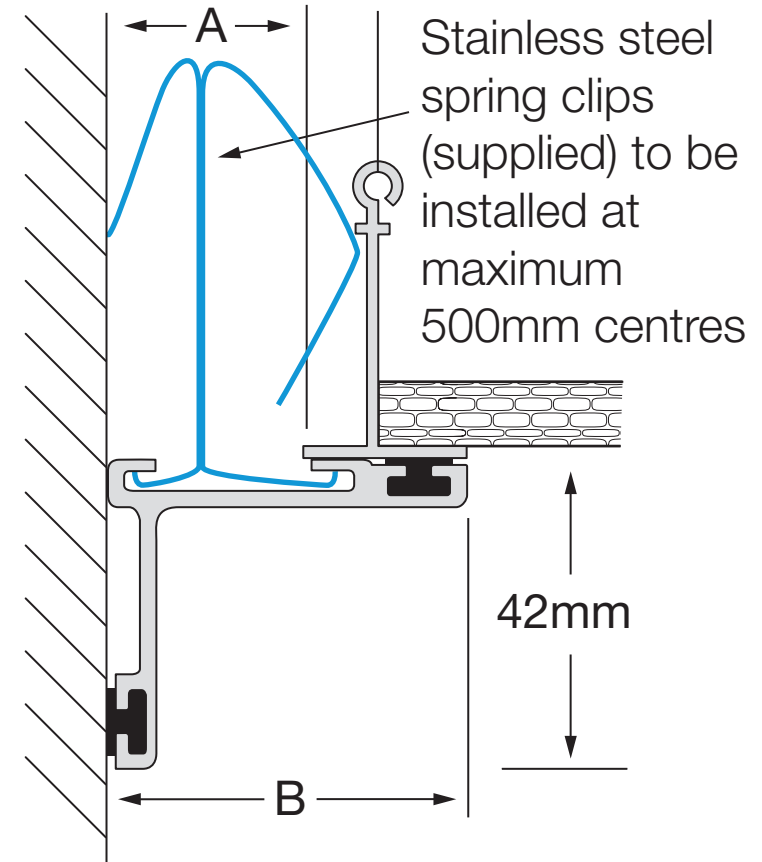

| Aluminium Code | A  | B  | Movement | Total Available Movement | Coverplate Depth |
|----------------|----|----|----------|--------------------------|------------------|
| Type 25SACL    | 25 | 53 | +/-12mm  | 25mm                     | 6mm              |
| Type 50SACL    | 50 | 90 | +/-15mm  | 30mm                     | 6mm              |

All dimensions are in millimetres.

Interior use only.  
 All mechanical expansion joint fixings by others.  
 Design subject to change without notice