

RCSL Carpet-Line Series - Standard

Flexible Expansion Joint Cover

LATHAM AUSTRALIA PTY LTD
 14 TENNYSON ROAD GLADESVILLE 2111 AUSTRALIA
 Phone: 61 2 9879 7888 Fax: 61 2 9879 7666
 Web: www.latham-australia.com



Illustrated: RCSL-25 Scale: Approx. Full Size
 All dimensions are to be verified before construction
 Verified By..... Date.....

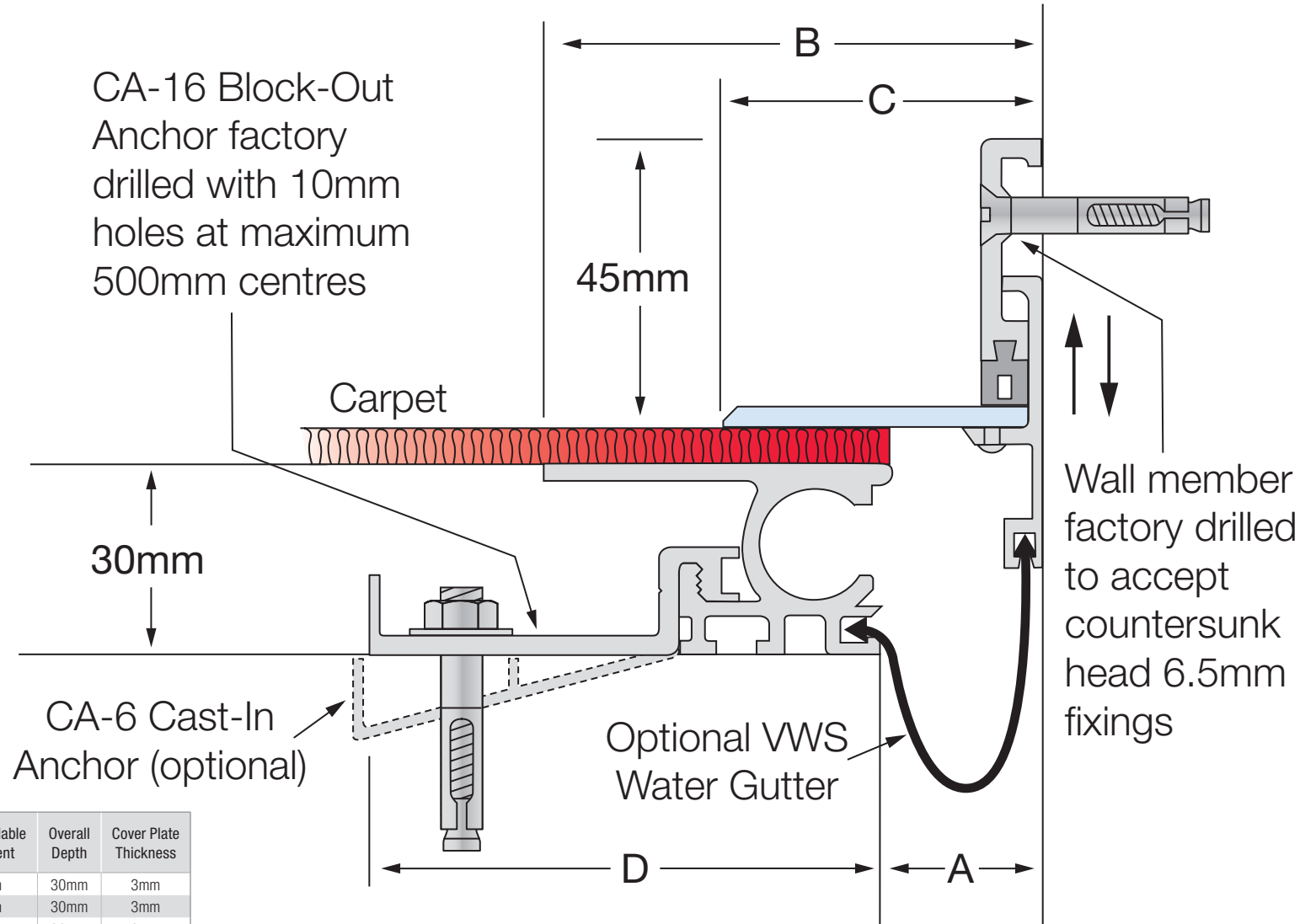

Stainless Steel Code smooth deck	A	B	C	D	Movement	Total Available Movement	Overall Depth	Cover Plate Thickness
RCSL-25	25	79	50	82	+/-12mm	25mm	30mm	3mm
RCSL-50	50	104	75	82	+/-12mm	25mm	30mm	3mm
RCSL-75	75	129	100	82	+/-12mm	25mm	30mm	3mm
RCSL-100	100	154	125	82	+/-12mm	25mm	30mm	3mm
RCSL-150	150	204	175	82	+/-12mm	25mm	30mm	4mm
RCSL-200	200	254	225	82	+/-12mm	25mm	30mm	4mm
RCSL-250	250	304	275	82	+/-12mm	25mm	30mm	5mm
RCSL-300	300	354	325	82	+/-12mm	25mm	30mm	5mm

All dimensions are in millimetres.

Interior applications only.
 All mechanical expansion joint fixings by others.
 Aluminium embedded members with stainless steel cover plate.
 Design subject to change without notice

COPYRIGHT © 2009

LATH3513