

NBDSL Flat-Line Series - No Bump

Flexible Expansion Joint Cover

LATHAM AUSTRALIA PTY LTD
 14 TENNYSON ROAD GLADESVILLE 2111 AUSTRALIA
 Phone: 61 2 9879 7888 Fax: 61 2 9879 7666
 Web: www.latham-australia.com



Illustrated: NBDSL-105 Scale: Approx. 80% Full Size
 All dimensions are to be verified before construction

Verified By..... Date.....

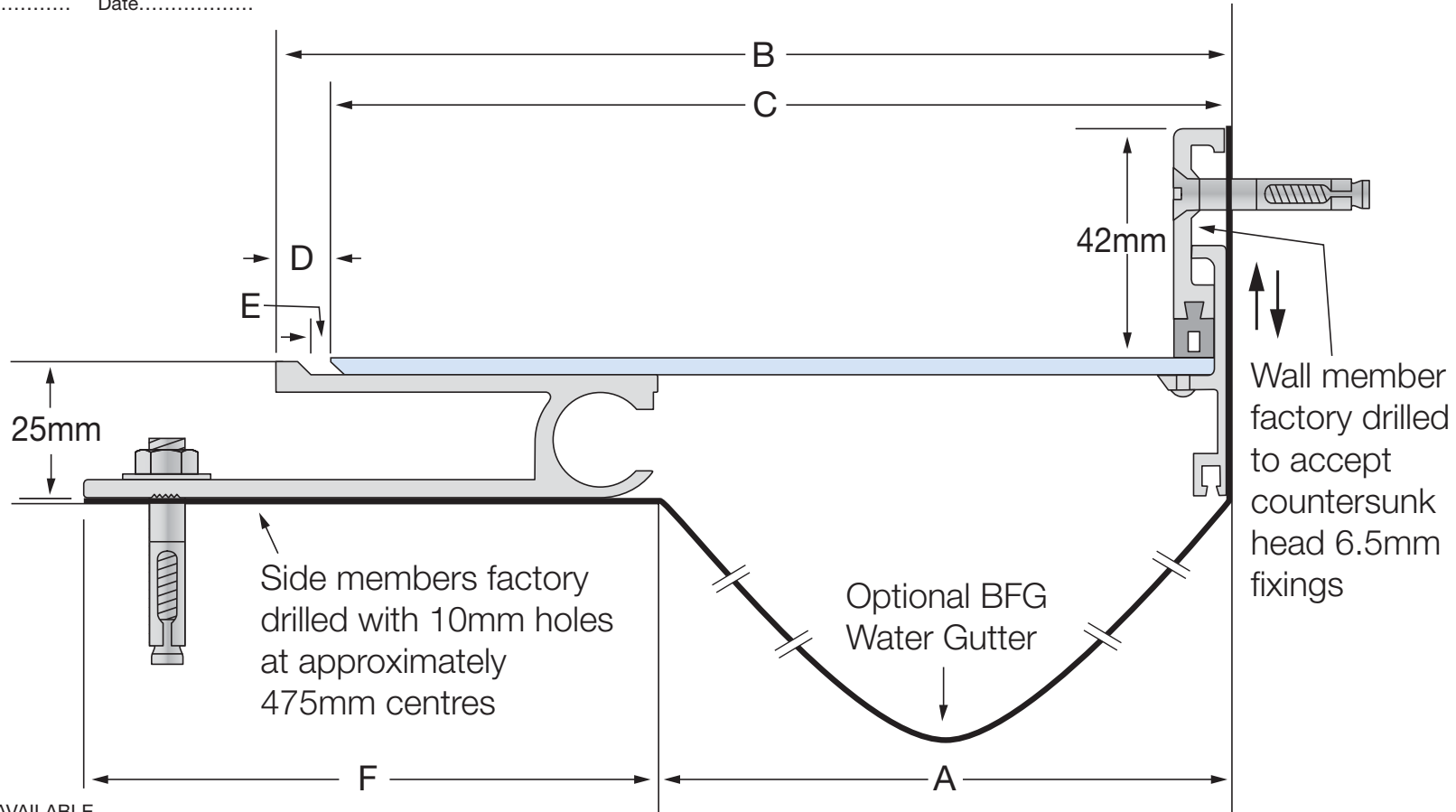

OPTIONAL HEIGHTS AVAILABLE

Standard: 25mm
 Optional: 32mm, 54mm, 64mm, 79mm, 89mm,
 104mm, 114mm, 139mm, 164mm

Stainless Steel Code	A	B	C	D	E	F	Movement	Total Available Movement	Overall Depth	Cover Plate Thickness
NBDSL-105	105	186	176	10	4	105	+61/-4mm	65mm	25mm	3mm
NBDSL-130	130	211	201	10	4	105	+61/-4mm	65mm	25mm	3mm

Larger joint widths available on request. All dimensions are in millimetres.

Exterior/Interior use.

The Latham No-Bump Series of joints have been specially designed by Latham Australia Pty. Ltd. for use in Hospitals and other applications where no change in floor surface level can be tolerated. The inverted Stainless Steel Cover Plate alleviates any bump. NBDS joints are available in all standard joint widths, as CS and DCS joints, please refer to Latham Technical Manual 43.

All mechanical expansion joint fixings by others.

Aluminium embedded members with stainless steel cover plate.

Design subject to change without notice.

COPYRIGHT © 2011

LATH3513