

LAB Brass Ultimate Series - Standard

Flexible Expansion Joint Cover

LATHAM AUSTRALIA PTY LTD
 14 TENNYSON ROAD GLADESVILLE 2111 AUSTRALIA
 Phone: 61 2 9879 7888 Fax: 61 2 9879 7666
 Web: www.latham-australia.com



Illustrated: LAB-25 Scale: Approx. Full Size
 All dimensions are to be verified before construction
 Verified By..... Date.....

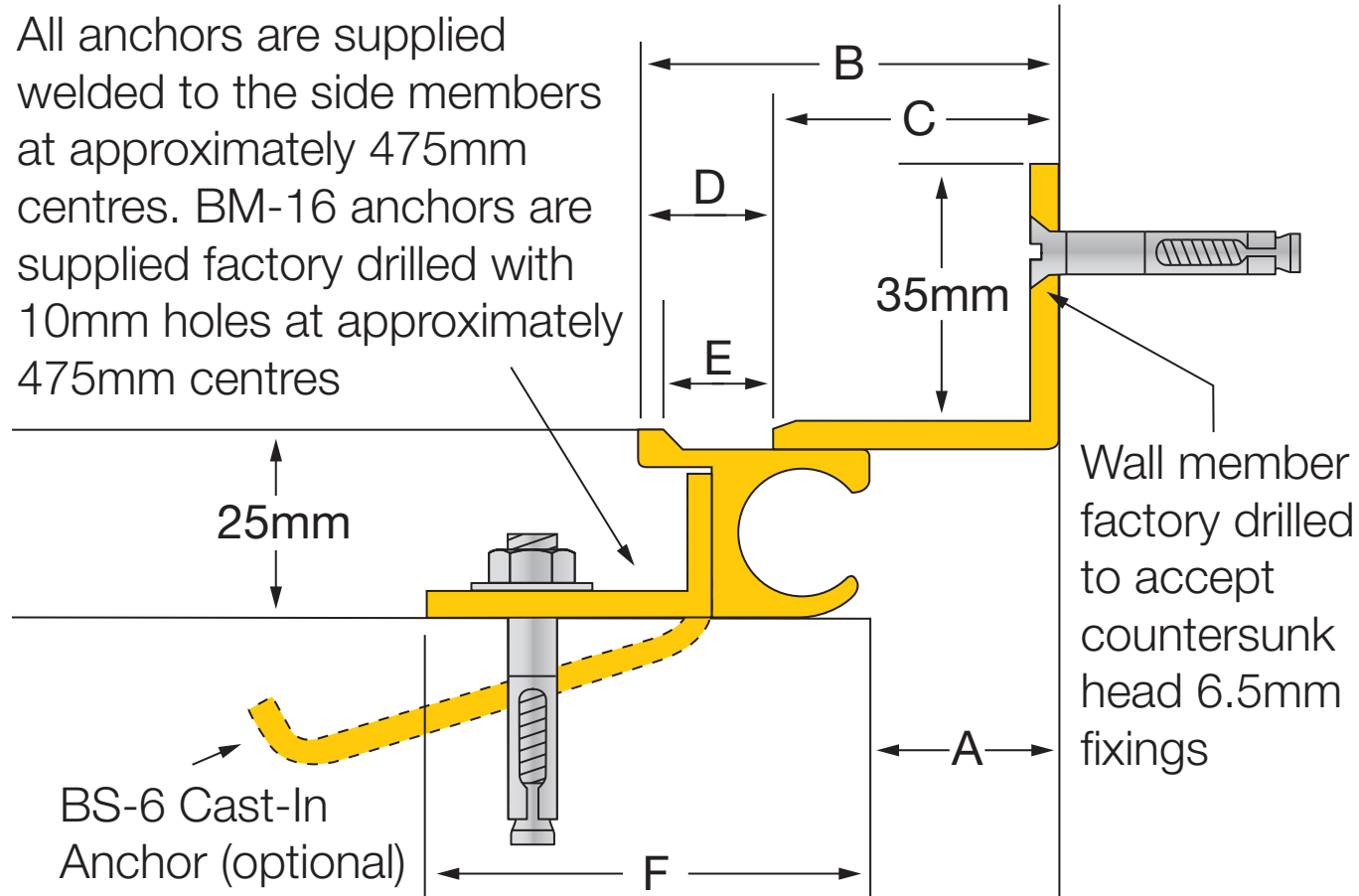

Solid Brass Code smooth deck	A	B	C	D	E	F	Movement	Total Available Movement	Overall Depth	Cover Plate Thickness
LAB-25	25	56	38	18	12	58	+/-12mm	24mm	25mm	3mm
LAB-50	50	82	64	18	12	58	+/-12mm	24mm	25mm	3mm

All dimensions are in millimetres.

Exterior/Interior use.
 All mechanical expansion joint fixings by others.
 Design subject to change without notice