

GXSL Surface-Line Series - Tapered Edge

Flexible Expansion Joint Cover

LATHAM AUSTRALIA PTY LTD
 14 TENNYSON ROAD GLADESVILLE 2111 AUSTRALIA
 Phone: 61 2 9879 7888 Fax: 61 2 9879 7666
 Web: www.latham-australia.com



Illustrated: GXSL-25 Scale: Approx. Full Size
 All dimensions are to be verified before construction

Verified By..... Date.....

Side member
 factory drilled to
 accept countersunk
 head 6.5mm fixings
 at approximately
 475mm centres

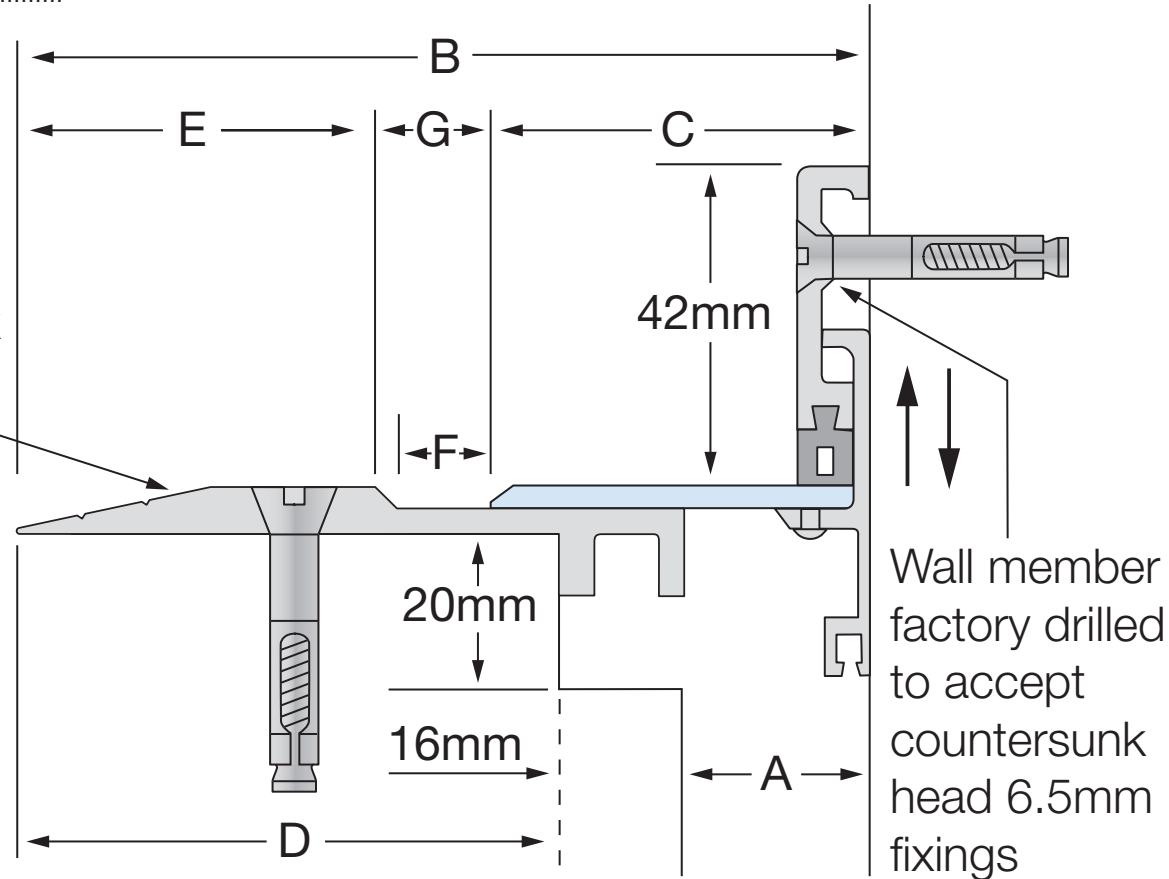

Wall member
 factory drilled
 to accept
 countersunk
 head 6.5mm
 fixings

Stainless Steel Code smooth deck	A	B	C	D	E	F	G	Movement	Total Available Movement	Overall Depth	Cover Plate Thickness
GXSL-25	25	113	50	70	45	15	18	+20/-15mm	35mm	Surface Mounted	3mm
GXSL-50	50	136	75	70	45	15	18	+20/-15mm	35mm	Surface Mounted	3mm
GXSL-75	75	163	100	70	45	15	18	+20/-15mm	35mm	Surface Mounted	3mm
GXSL-100	100	188	125	70	45	15	18	+20/-15mm	35mm	Surface Mounted	3mm
GXSL-150	150	238	175	70	45	15	18	+20/-15mm	35mm	Surface Mounted	4mm

Wider joint widths available on request. All dimensions are in millimetres.

Exterior/Interior use.
 All mechanical expansion joint fixings by others.
 Aluminium side members with stainless steel cover plate.
 Design subject to change without notice.