

# EXAL Surface-Line Series - Standard

Flexible Expansion Joint Cover

**LATHAM AUSTRALIA PTY LTD**  
 14 TENNYSON ROAD GLADESVILLE 2111 AUSTRALIA  
 Phone: 61 2 9879 7888 Fax: 61 2 9879 7666  
 Web: www.latham-australia.com



Illustrated: EXAL-25 Scale: Approx. Full Size  
 All dimensions are to be verified before construction

Verified By..... Date.....

Side member factory drilled to accept countersunk head 6.5mm fixings at approximately 475mm centres

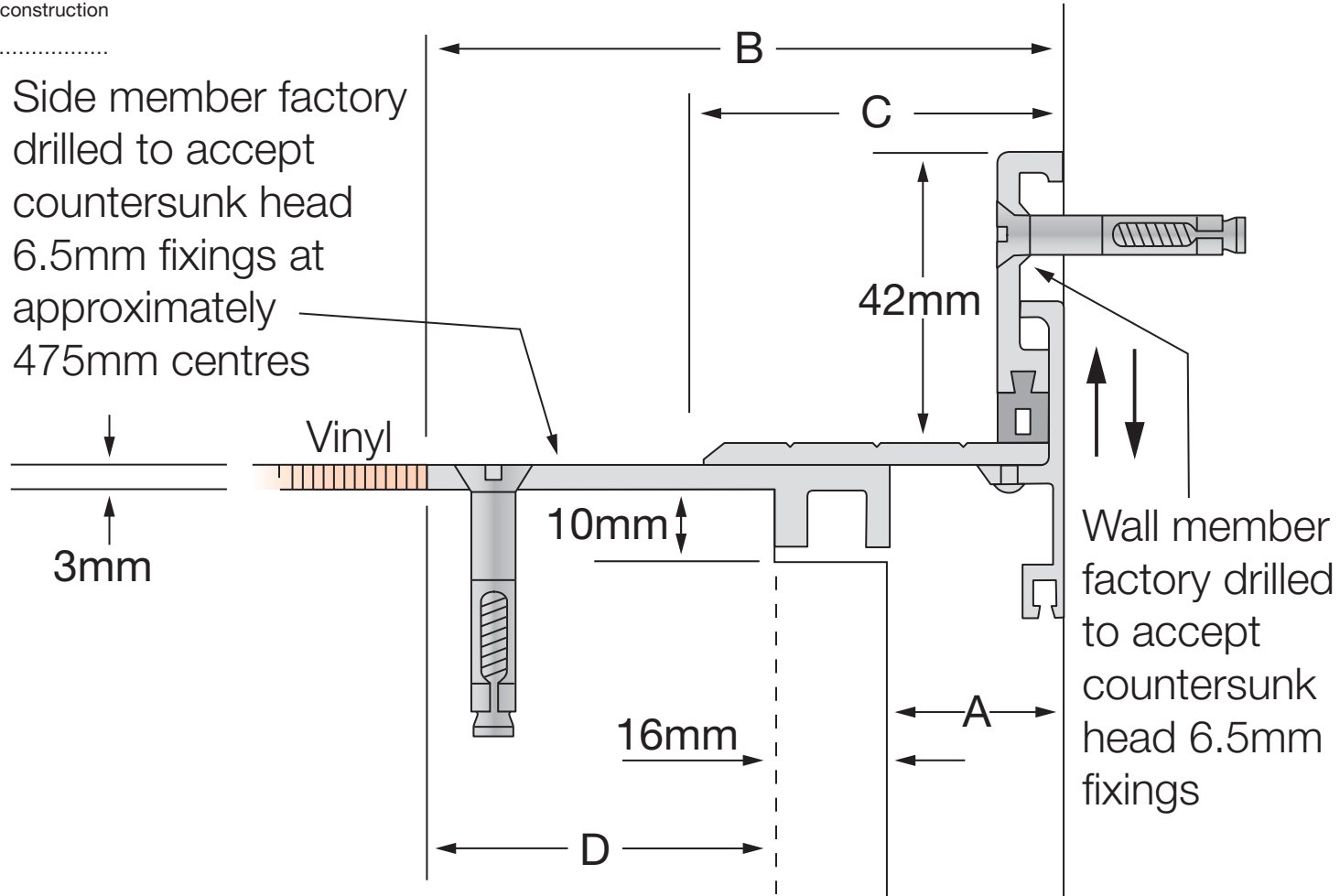

Aluminium Code ribbed deck	A	B	C	D	Movement	Total Available Movement	Overall Depth	Cover Plate Thickness
EXAL-25	25	85	90	49	+/-20mm	40mm	Surface Mounted	3mm
EXAL-50	50	110	115	49	+/-20mm	40mm	Surface Mounted	3mm
EXAL-75	75	135	140	49	+/-20mm	40mm	Surface Mounted	3mm
EXAL-100	100	160	165	49	+/-20mm	40mm	Surface Mounted	3mm
EXAL-150	150	210	215	49	+/-20mm	40mm	Surface Mounted	4mm

Larger movement capabilities and joint widths available on request, All dimensions are in millimetres.

Exterior/Interior use.  
 All mechanical expansion joint fixings by others.  
 Design subject to change without notice.

COPYRIGHT © 2009

LATH3513