

EXA Surface-Line Series - Standard

Flexible Expansion Joint Cover

LATHAM AUSTRALIA PTY LTD
 14 TENNYSON ROAD GLADESVILLE 2111 AUSTRALIA
 Phone: 61 2 9879 7888 Fax: 61 2 9879 7666
 Web: www.latham-australia.com



Illustrated: EXA-25 Scale: Approx. Full Size
 All dimensions are to be verified before construction

Verified By..... Date.....

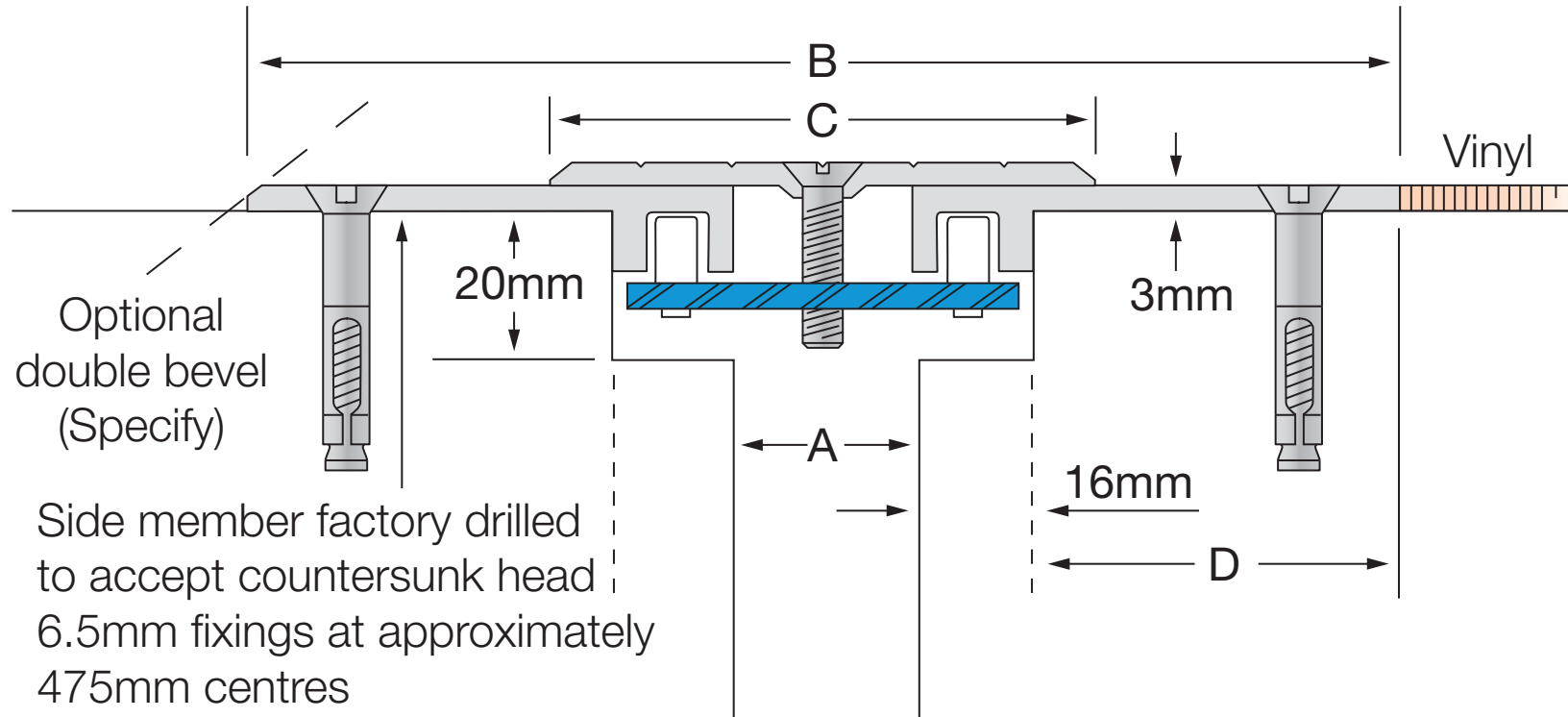

Aluminium Code ribbed deck	A	B	C	D	Movement	Total Available Movement	Overall Depth	Cover Plate Thickness
EXA-25	25	155	75	49	+25/-15mm	40mm	Surface Mounted	3mm
EXA-50	50	180	100	49	+/-25mm	50mm	Surface Mounted	3mm
EXA-75	75	205	125	49	+/-25mm	50mm	Surface Mounted	3mm
EXA-100	100	235	150	49	+/-25mm	50mm	Surface Mounted	3mm
EXA-150	150	335	200	49	+/-25mm	50mm	Surface Mounted	4mm

Larger movement capabilities and joint widths available on request. All dimensions are in millimetres.

Exterior/Interior use.

All mechanical expansion joint fixings by others.

The centering bar consists of two elongated spherical rods fastened at opposite ends of a flat spring steel bar. The bar is positioned diagonally across the joint opening with the elongated spherical rods inside the extruded tracks. This unique concept allows for increased rotational movements and maintains constant spring tension at the centre of the cover plate. This greatly reduces the stresses on the embedded anchor sections and the surrounding concrete slabs.

Design subject to change without notice.

COPYRIGHT © 2009

LATH3513