

70 Series Resilient Light Duty

Flexible Expansion Joint Cover

LATHAM AUSTRALIA PTY LTD
 14 TENNYSON ROAD GLADESVILLE 2111 AUSTRALIA
 Phone: 61 2 9879 7888 Fax: 61 2 9879 7666
 Web: www.latham-australia.com



Scale: Approx. 33% Full Size
 All dimensions are to be verified before construction

Verified By..... Date.....

70-FDRW

70-FDR

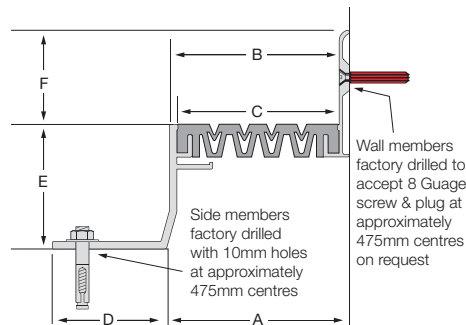
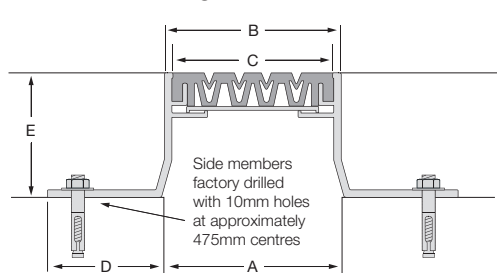

70-FDR (30)

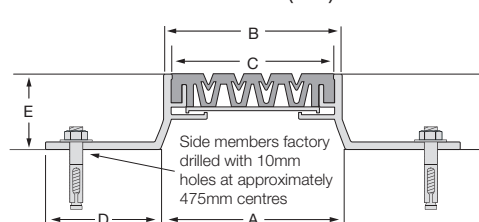

70-FDRW (30)

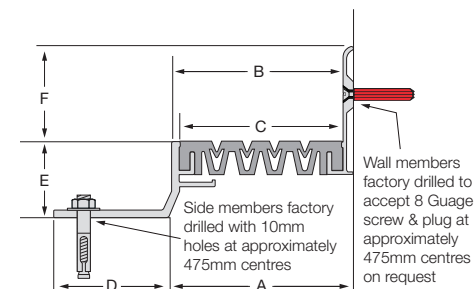

| Aluminium Code | A | B | C | D | E | F | Movement | Total Available Movement | Overall Depth |
|----------------|----|----|----|----|----|----|----------|--------------------------|---------------|
| 70-FDR | 70 | 71 | 65 | 50 | 50 | | +/-10mm | 20mm | 50mm |
| 70-FDRW | 70 | 68 | 65 | 50 | 50 | 38 | +/-10mm | 20mm | 88mm |

All dimensions are in millimetres.

| Aluminium Code | A | B | C | D | E | F | Movement | Total Available Movement | Overall Depth |
|----------------|----|----|----|----|----|----|----------|--------------------------|---------------|
| 70-FDR (30) | 70 | 71 | 65 | 50 | 30 | | +/-10mm | 20mm | 30mm |
| 70-FDRW (30) | 70 | 68 | 65 | 50 | 30 | 38 | +/-10mm | 20mm | 68mm |

All dimensions are in millimetres.

70-FDRW (20)

70-FDR (20)

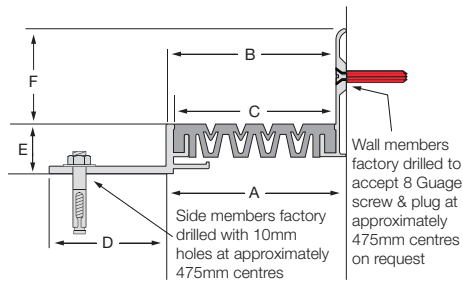
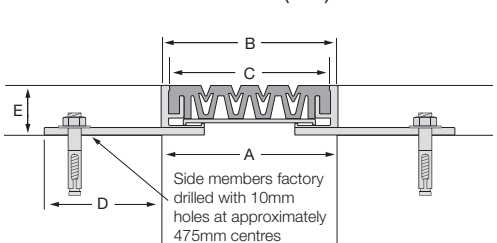

| Aluminium Code | A | B | C | D | E | F | Movement | Total Available Movement | Overall Depth |
|----------------|----|----|----|----|----|----|----------|--------------------------|---------------|
| 70-FDR (20) | 70 | 71 | 65 | 50 | 20 | | +/-10mm | 20mm | 20mm |
| 70-FDRW (20) | 70 | 68 | 65 | 50 | 20 | 38 | +/-10mm | 20mm | 58mm |

All dimensions are in millimetres.

Interior applications only.

All mechanical expansion joint fixings by others.

Design subject to change without notice

COPYRIGHT © 2009

LATH3513

B70 Series Resilient Light Duty Flexible Expansion Joint Cover

LATHAM AUSTRALIA PTY LTD
 14 TENNYSON ROAD GLADESVILLE 2111 AUSTRALIA
 Phone: 61 2 9879 7888 Fax: 61 2 9879 7666
 Web: www.latham-australia.com



Scale: Approx. 33% Full Size
 All dimensions are to be verified before construction

Verified By..... Date.....

B70-FDRW

B70-FDR

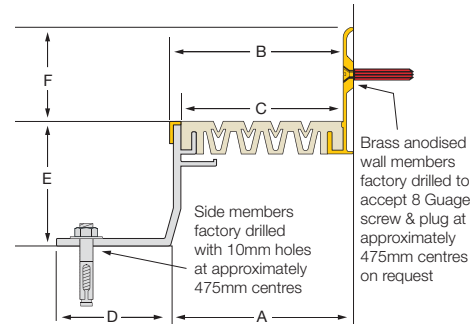
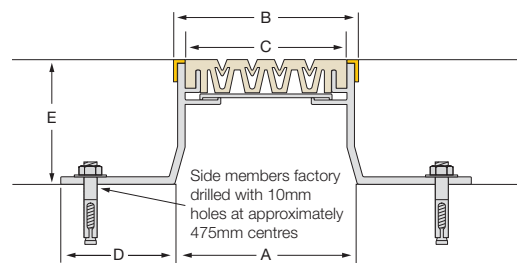

B70-FDR (30)

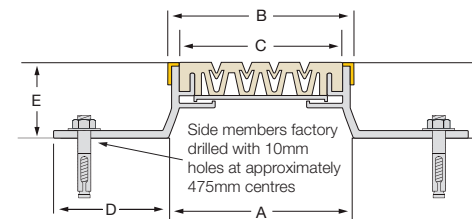

B70-FDRW (30)

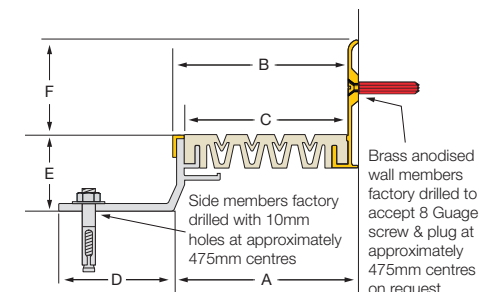

| Aluminium Code | A | B | C | D | E | F | Movement | Total Available Movement | Overall Depth |
|----------------|----|----|----|----|----|----|----------|--------------------------|---------------|
| B70-FDR | 70 | 75 | 65 | 50 | 51 | | +/-10mm | 20mm | 50mm |
| B70-FDRW | 70 | 70 | 65 | 50 | 51 | 38 | +/-10mm | 20mm | 89mm |

All dimensions are in millimetres.

| Aluminium Code | A | B | C | D | E | F | Movement | Total Available Movement | Overall Depth |
|----------------|----|----|----|----|----|----|----------|--------------------------|---------------|
| B70-FDR (30) | 70 | 75 | 65 | 50 | 31 | | +/-10mm | 20mm | 31mm |
| B70-FDRW (30) | 70 | 70 | 65 | 50 | 31 | 38 | +/-10mm | 20mm | 69mm |

All dimensions are in millimetres.

B70-FDRW (20)

B70-FDR (20)

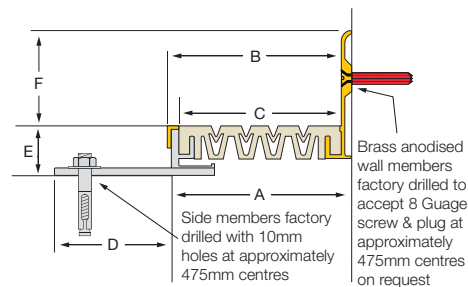
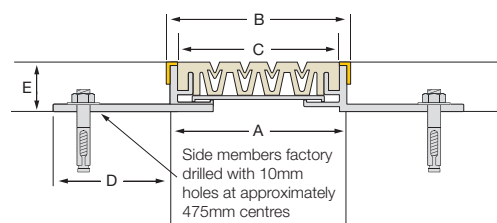

| Aluminium Code | A | B | C | D | E | F | Movement | Total Available Movement | Overall Depth |
|----------------|----|----|----|----|----|----|----------|--------------------------|---------------|
| B70-FDR (20) | 70 | 75 | 65 | 50 | 21 | | +/-10mm | 20mm | 20mm |
| B70-FDRW (20) | 70 | 70 | 65 | 50 | 21 | 38 | +/-10mm | 20mm | 59mm |

All dimensions are in millimetres.

Interior applications only.

All mechanical expansion joint fixings by others.

Design subject to change without notice

COPYRIGHT © 2009

LATH3513